

Classical Model of Confinement

Y.P. Goncharov · N.E. Firsova

Received: 19 December 2009 / Accepted: 25 February 2010 / Published online: 19 March 2010
© Springer Science+Business Media, LLC 2010

Abstract The confinement mechanism proposed earlier and then applied successfully to meson spectroscopy by one of the authors is interpreted in classical terms. For this aim the unique solution of the Maxwell equations, an analog of the corresponding unique solution of the SU(3)-Yang-Mills equations describing linear confinement in quantum chromodynamics, is used. Motion of a charged particle is studied in the field representing magnetic part of the mentioned solution and it is shown that one deals with the full classical confinement of the charged particle in such a field: under any initial conditions the particle motion is accomplished within a finite region of space so that the particle trajectory is near magnetic field lines while the latter are compact manifolds (circles). An asymptotical expansion for the trajectory form in the strong field limit is adduced. The possible application of the obtained results in thermonuclear plasma physics is also shortly outlined.

Keywords Quantum chromodynamics · Confinement · Thermonuclear plasma physics

1 Introduction

In [1–3] for the Dirac-Yang-Mills system derived from QCD-Lagrangian an unique family of compatible nonperturbative solutions was found and explored, which could pretend to describing confinement of two quarks. The successful applications of the family to the description of both the heavy quarkonia spectra [4–7] and a number of properties of pions, kaons, η and η' -meson [8–12] showed that the confinement mechanism is qualitatively the same for both light mesons and heavy quarkonia and it is mainly governed by the magnetic

Y.P. Goncharov (✉)
Theoretical Group, Experimental Physics Department, State Polytechnical University,
Sankt-Petersburg 195251, Russia
e-mail: ygonch@chem.hop.stu.neva.ru

N.E. Firsova
Institute of the Mechanical Engineering Problems, Russian Academy of Sciences,
Sankt-Petersburg 199178, Russia
e-mail: nef2@mail.ru

colour field linear in r (distance between quarks) which represents a part of the mentioned unique family of solutions and, in its turn, the part is a solution of the SU(3)-Yang-Mills equations.

As has been emphasized, however, as far back as in [2, 3], the similar unique confining solutions exist for any compact semisimple and non-semisimple Lie groups, in particular, for SU(N)-groups with $N \geq 2$ and for U(N)-groups with $N \geq 1$, i.e. it holds true also for classical electrodynamics with group U(1) and Maxwell equations. Under this situation, as was pointed out in [2, 3], there is an interesting possibility of indirect experimental verification of the confinement mechanism under discussion. Indeed the confining solutions of Maxwell equations for classical electrodynamics point out the confinement phase could be in electrodynamics as well. Though there exist no elementary charged particles generating a constant magnetic field linear in r , the distance from particle, after all, if it could generate this electromagnetic field configuration in laboratory then one might study motion of the charged particles in that field. The confining properties of the mentioned field should be displayed at classical level too but the exact behaviour of particles in this field requires certain analysis of the corresponding classical equations of motion.

The aim of the present paper is to some degree to realize the above program on studying motion of the charged particles in the mentioned confining electromagnetic field.

Section 2 contains preliminaries necessary to pose the problem: information on the confining solutions of the Yang-Mills and Maxwell equations and on the miscellaneous forms of the motion equations for a charged particle in the confining magnetic field when considering it with using different curvilinear coordinates. Section 3 is devoted to the general conclusions of a qualitative character concerning behaviour of a charged particle in the magnetic field under discussion. In the strong field limit Sect. 4 gives asymptotical expansions for the spherical coordinates of a particle when its moving in the field under consideration while Sect. 5 contains numerical estimates and Sect. 6 is devoted to discussion and concluding remarks.

Appendix A is devoted to the formulation of vector analysis on a region Ω in \mathbb{R}^3 which is most convenient, especially while working with using the arbitrary curvilinear coordinates so the mentioned formulation is employed throughout the paper. At last, Appendix B supplements Sect. 2 with a proof of the uniqueness theorem from that section in the case of U(1)-group (Maxwell equations).

Also throughout the paper we employ the Heaviside-Lorentz system of units with $\hbar = c = 1$ and also with the Boltzmann constant $k = 1$, unless explicitly stated otherwise. When calculating we apply the relations $1 \text{ GeV}^{-1} \approx 0.1973269679 \text{ fm}$, $1 \text{ s}^{-1} \approx 0.658211915 \times 10^{-24} \text{ GeV}$, $1 \text{ V/m} \approx 0.2309956375 \times 10^{-23} \text{ GeV}^2$, $1 \text{ T} = 4\pi \times 10^{-7} \text{ H/m} \times 1 \text{ A/m} \approx 0.6925075988 \times 10^{-15} \text{ GeV}^2$.

2 Preliminaries

2.1 The Confining Solutions of SU(3)-Yang-Mills and Maxwell Equations

As was mentioned above, our study is motivated by the confinement mechanism proposed earlier by one of the authors and based on the unique family of compatible nonperturbative solutions for the Dirac-Yang-Mills system (derived from QCD-Lagrangian) studied at the whole length in [1–3].

One part of the mentioned family is presented by the unique nonperturbative confining solution of the SU(3)-Yang-Mills equations for gluonic field $A = A_\mu dx^\mu = A_\mu^a \lambda_a dx^\mu$ (λ_a

are the known Gell-Mann matrices, $\mu = t, r, \vartheta, \varphi, a = 1, \dots, 8$). To specify the question, let us note that in general the Yang-Mills equations on a manifold M can be written as

$$d * F = g(*F \wedge A - A \wedge *F), \tag{1}$$

where the curvature matrix (field strength) $F = dA + gA \wedge A = F_{\mu\nu}^a \lambda_a dx^\mu \wedge dx^\nu$ with exterior differential d and the Cartan’s (exterior) product \wedge , while $*$ means the Hodge star operator conforming to a metric on manifold under consideration, g is a gauge coupling constant.

The most important case of M is Minkowski spacetime and we are interested in the confining solutions A of the SU(3)-Yang-Mills equations. The confining solutions were defined in [1] as the spherically symmetric solutions of the Yang-Mills equations (1) containing only the components of the SU(3)-field which are Coulomb-like or linear in r . Additionally we impose the Lorentz condition on the sought solutions. The latter condition is necessary for quantizing the gauge fields consistently within the framework of perturbation theory (see, e.g. [13]), so we should impose the given condition that can be written in the form $\text{div}(A) = 0$, where the divergence of the Lie algebra valued 1-form $A = A_\mu dx^\mu = A_\mu^a \lambda_a dx^\mu$ is defined by the relation (see, e.g., [19, 20])

$$\text{div}(A) = \frac{1}{\sqrt{\delta}} \partial_\mu (\sqrt{\delta} g^{\mu\nu} A_\nu). \tag{2}$$

It should be emphasized that, from the physical point of view, the Lorentz condition reflects the fact of transversality for gluons that arise as quanta of SU(3)-Yang-Mills field when quantizing the latter (see, e.g., [13]).

Under the circumstances, the unique nonperturbative confining solution of the SU(3)-Yang-Mills equations looks as follows

$$\begin{aligned} A_t^3 + \frac{1}{\sqrt{3}} A_t^8 &= -\frac{a_1}{r} + A_1, & -A_t^3 + \frac{1}{\sqrt{3}} A_t^8 &= -\frac{a_2}{r} + A_2, \\ -\frac{2}{\sqrt{3}} A_t^8 &= \frac{a_1 + a_2}{r} - (A_1 + A_2), \\ A_\varphi^3 + \frac{1}{\sqrt{3}} A_\varphi^8 &= b_1 r + B_1, & -A_\varphi^3 + \frac{1}{\sqrt{3}} A_\varphi^8 &= b_2 r + B_2, \\ -\frac{2}{\sqrt{3}} A_\varphi^8 &= -(b_1 + b_2)r - (B_1 + B_2) \end{aligned} \tag{3}$$

with the real constants a_j, A_j, b_j, B_j parametrizing the family. As has been repeatedly discussed by us earlier (see, e.g., [2, 3] and below), from the above form it is clear that the solution (3) is a configuration describing the electric Coulomb-like colour field (components $A_t^{3,8}$) and the magnetic colour field linear in r (components $A_\varphi^{3,8}$) and we wrote down the solution (3) in the combinations that are just needed further to insert into the corresponding Dirac equation (for more details see [1–3]).

The word *unique* should be understood in the strict mathematical sense. In fact in [2] the following theorem was proved (see also Appendix B):

The unique exact spherically symmetric (nonperturbative) confining solutions (depending only on r and r^{-1}) of SU(3)-Yang-Mills equations in Minkowski spacetime consist of the family of (3).

It should be noted that solution (3) was found early in [1] but its uniqueness was proved just in [2] (see also [3]). Besides, in [2] it was shown that the above unique confining solutions (3) satisfy the so-called Wilson confinement criterion [14, 15]. Up to now nobody contested this result so if we want to describe interaction between quarks by spherically symmetric confining SU(3)-fields then they can be only those from the above theorem.

Now one should say that the similar unique confining solutions exist for all semisimple and non-semisimple compact Lie groups, in particular, for SU(N) with $N \geq 2$ and U(N) with $N \geq 1$ [2, 3]. Explicit form of solutions, e.g., for SU(N) with $N = 2, 4$ can be found in [3] but it should be emphasized that components linear in r always represent the magnetic (colour) field in all the mentioned solutions. Within the present paper we are especially interested in the U(1)-case (electrodynamics) and a proof of the above uniqueness theorem for that situation is adduced in Appendix B for inquiring.

Under this situation the Yang-Mills equations (1) turn into the second pair of Maxwell equations

$$d * F = 0 \tag{4}$$

with $F = dA$, $A = A_\mu dx^\mu$. As is discussed in Appendix B, in the spherically symmetric case the equations (4) are equivalent to

$$\partial_r(r^2 \partial_r A_t) = 0, \quad \partial_r^2 A_\varphi = 0, \tag{5}$$

with $A_t = A_t(r)$, $A_\varphi = A_\varphi(r)$ and we write down the unique solutions of (5) as

$$A_t = \frac{a}{r} + A, \quad A_\varphi = br + B \tag{6}$$

with some constants a, b, A, B parametrizing solutions.

To interpret solutions (6) in the more habitual physical terms let us pass on to Cartesian coordinates employing the relations

$$\varphi = \arctan(y/x), \quad d\varphi = \frac{\partial\varphi}{\partial x} dx + \frac{\partial\varphi}{\partial y} dy \tag{7}$$

which entails

$$\mathbf{A} = A_\varphi d\varphi = (br + B)d\varphi = -\frac{(br + B)y}{x^2 + y^2} dx + \frac{(br + B)x}{x^2 + y^2} dy \tag{8}$$

and we conclude that the solutions (6) describe the combination of the electric Coulomb field with potential $\Phi = A_t$ and the constant magnetic field with the vector-potential (8) which can be written as (using isomorphism $dx \iff \mathbf{i}, dy \iff \mathbf{j}, dz \iff \mathbf{k}$, see Appendix A)

$$\mathbf{A} = A_x \mathbf{i} + A_y \mathbf{j} + A_z \mathbf{k} = -\frac{(br + B)y}{x^2 + y^2} \mathbf{i} + \frac{(br + B)x}{x^2 + y^2} \mathbf{j}, \tag{9}$$

which is *linear* in r in spherical coordinates. Let us compute 3-dimensional divergence $\text{div} \mathbf{A}$ with the help of 3-dimensional Hodge star operator (see Appendix A). In spherical coordinates we have (see (A.12) and (A.7))

$$\text{div} \mathbf{A} = *(d * \mathbf{A}) = *d * [(br + B)d\varphi] = *d \left(\frac{br + B}{\sin \vartheta} dr \wedge d\vartheta \right) = 0.$$

Then (4) in Cartesian coordinates take the form

$$\Delta \Phi = 0, \quad \text{rot rot} \mathbf{A} = \text{grad div} \mathbf{A} - \Delta \mathbf{A} = -\Delta \mathbf{A} = 0 \tag{10}$$

with the Laplace operator $\Delta = \partial_x^2 + \partial_y^2 + \partial_z^2$. Also it is easy to check that the solution under consideration satisfies the 4-dimensional Lorentz condition $\text{div}(\mathbf{A}) = 0$, where 4-dimensional divergence is defined by (2).

Finally, as is shown in Appendix A, the corresponding strength of magnetic field is

$$\begin{aligned} \mathbf{H} = \text{rot} \mathbf{A} = *(d\mathbf{A}) &= -\frac{b}{\sin \vartheta} d\vartheta = -\frac{b}{r} \left(\frac{xz}{x^2 + y^2} dx + \frac{yz}{x^2 + y^2} dy - dz \right) \\ \iff -\frac{b}{r} \left(\frac{xz}{x^2 + y^2} \mathbf{i} + \frac{yz}{x^2 + y^2} \mathbf{j} - \mathbf{k} \right), \end{aligned} \tag{11}$$

respectively, in spherical and Cartesian coordinates.

2.2 Singularities of Solutions

As is seen from (8) and (11), the magnetic field under exploration has the singularities on the z -axis so its formal mathematical definition domain is the manifold $\mathbb{R}^3 \setminus \{z\}$ with the z -axis discarded rather than the manifold \mathbb{R}^3 . Singularities of such a kind are of mathematical nature and appear when trying to write a *concrete macroscopic physical field* in an analytical form. Physical origin of the given singularities is that some sources generating the field should be present on z -axis. Another matter is that the field under consideration may probably be modelled by miscellaneous ways. For the sake of completeness, one of possible physical realization will be considered in Sect. 6. In theoretical considerations within classical approach one should segregate from a concrete realization of one or another macroscopic electromagnetic field and consider them to be given on their natural mathematical definition domains.

At the quantum level, however, treatment of singularities may be different from classical one. In particular, in the case of gluonic field (3) the problem of singularity along z -axis of magnetic part for solution (3) can be resolved by that quarks may emit gluons outside of some cone $\vartheta = \vartheta_0$ so singularity along z -axis plays no role (for more details see [12] and estimates for ϑ_0 in pions and kaons therein).

2.3 Equations of Motion for a Charged Particle in the Confining Magnetic Field

As was mentioned in Sect. 1, at quantum level the confinement of quarks is basically governed by the magnetic (colour) part (linear in r) of solution (3), as has been discussed in [4–12]. In the present paper we would like, at classical level, to explore the behaviour of a charged particle moving in the confining magnetic field (11). Accordingly, we need to study classical equations of motion for such a particle. As is known (see, e.g., [16]), those equations are obtained from Lagrangian

$$L = -m\sqrt{1 - v^2} + q\mathbf{A}\mathbf{v}, \tag{12}$$

where q and m are, respectively, charge and mass of a particle while the form of both the velocity square $v^2 = g^{\mu\nu} v_\mu v_\nu$ and the scalar product $\mathbf{A}\mathbf{v} = g^{\mu\nu} A_\mu v_\nu$ depends on choice of

curvilinear coordinates. Then the sought equations are derived from (12) according to the standard prescription of Lagrange approach as

$$\frac{d}{dt} \left(\frac{\partial L}{\partial \dot{Q}_i} \right) - \left(\frac{\partial L}{\partial Q_i} \right) = 0, \quad i = 1, 2, 3, \tag{13}$$

where Q_i are the chosen coordinates and the dot signifies differentiation with respect to t . For our purposes the equations of motion will be useful in both spherical and Cartesian coordinates. One can note that v^2 is conserved [16] when moving in a constant magnetic field, i.e., the full energy $E = m/\sqrt{1 - v^2}$ of (relativistic) particle is also conserved. In the case of spherical coordinates we have $\mathbf{v} = \dot{r} dr + r^2 \dot{\vartheta} d\vartheta + r^2 \sin^2 \vartheta \dot{\varphi} d\varphi$, $v^2 = g^{\mu\nu} v_\mu v_\nu = \dot{r}^2 + r^2 \dot{\vartheta}^2 + r^2 \sin^2 \vartheta \dot{\varphi}^2 = v_0^2 = const$, $\mathbf{A} \mathbf{v} = g^{\varphi\varphi} A_\varphi v_\varphi = (br + B)\dot{\varphi}$ with \mathbf{A} from (8) and in accordance with (13) we obtain

$$\mu(\ddot{r} - r \sin^2 \vartheta \dot{\varphi}^2 - r \dot{\vartheta}^2) = \dot{\varphi}, \tag{14}$$

$$\frac{d}{dt}(r^2 \dot{\vartheta}) - r^2 \dot{\varphi}^2 \sin \vartheta \cos \vartheta = 0, \tag{15}$$

$$\mu \frac{d}{dt}(r^2 \dot{\varphi} \sin^2 \vartheta) = -\dot{r} \tag{16}$$

with dimensionless parameter $\mu = E/(qb)$. In the case of Cartesian coordinates we have $\mathbf{v} = \dot{x} dx + \dot{y} dy + \dot{z} dz$, $v^2 = \dot{x}^2 + \dot{y}^2 + \dot{z}^2 = v_0^2 = const$, $\mathbf{A} \mathbf{v} = -\dot{x} \frac{(br+B)y}{x^2+y^2} + \dot{y} \frac{(br+B)x}{x^2+y^2}$ with \mathbf{A} from (8)–(9) and (13) gives rise to

$$\mu \ddot{x} = \frac{1}{r} \left(\dot{y} + \dot{z} \frac{yz}{x^2 + y^2} \right), \tag{17}$$

$$\mu \ddot{y} = -\frac{1}{r} \left(\dot{x} + \dot{z} \frac{xz}{x^2 + y^2} \right), \tag{18}$$

$$\mu \ddot{z} = \frac{z}{r(x^2 + y^2)} (x\dot{y} - y\dot{x}). \tag{19}$$

Also we should add the initial conditions to (14)–(16) and (17)–(19). Namely, putting an initial moment of time $t_0 = 0$ for simplicity, we have, respectively,

$$r(0) = r_0, \quad \vartheta(0) = \vartheta_0, \quad \varphi(0) = \varphi_0, \quad \dot{r}(0) = \dot{r}_0, \quad \dot{\vartheta}(0) = \dot{\vartheta}_0, \quad \dot{\varphi}(0) = \dot{\varphi}_0 \tag{20}$$

or

$$x(0) = x_0, \quad y(0) = y_0, \quad z(0) = z_0, \quad \dot{x}(0) = \dot{x}_0, \quad \dot{y}(0) = \dot{y}_0, \quad \dot{z}(0) = \dot{z}_0. \tag{21}$$

3 General Considerations

3.1 Magnetic Field Lines

Let us above all find out how the magnetic field lines look for the field of (11). According to a general prescription (see, e.g., [21]) we should determine integral curves for differential

Fig. 1 Magnetic field lines of the confining magnetic field

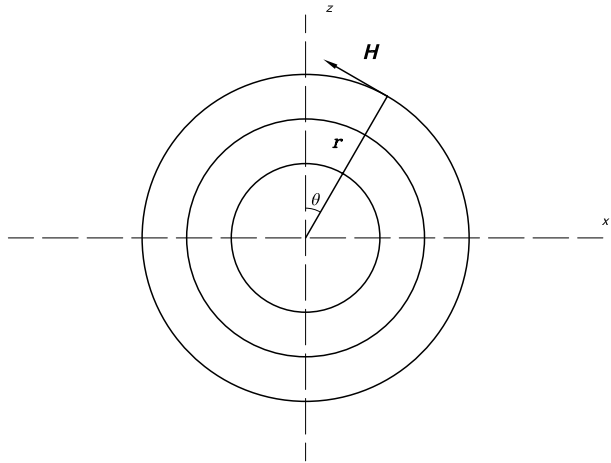

system

$$\frac{dx}{H_x} = \frac{dy}{H_y} = \frac{dz}{H_z}, \tag{22}$$

which can be made if finding the first integrals for it, i.e., such functions ψ that satisfy the partial differential equation

$$\frac{\partial \psi}{\partial x} H_x + \frac{\partial \psi}{\partial y} H_y + \frac{\partial \psi}{\partial z} H_z = 0. \tag{23}$$

Then, as is not complicated to check, the system (22) has two independent first integrals, namely $y = C_1 x, x^2 + y^2 + z^2 = C_2^2$ with constants $C_{1,2}$. That is, integral surfaces are planes and spheres and, as a result, integral curves are circles. For example, the plane $y = 0$ is integral surface and equations of field lines are $x^2 + z^2 = C_2^2$ (see Fig. 1).

3.2 The Confining Properties

We can note that

$$\frac{d^2}{dt^2} r^2 = \frac{d}{dt} (2r\dot{r}) = 2 \frac{d}{dt} (x\dot{x} + y\dot{y} + z\dot{z}) = 2[v^2 + (x\ddot{x} + y\ddot{y} + z\ddot{z})] \tag{24}$$

with $v^2 = \dot{x}^2 + \dot{y}^2 + \dot{z}^2$. Multiplying (17), (18), (19) by x, y, z , respectively, and adding the results, we get

$$\mu(x\ddot{x} + y\ddot{y} + z\ddot{z}) = \frac{x\dot{y} - y\dot{x}}{r} \left(1 + \frac{z^2}{x^2 + y^2} \right), \quad \mu = \frac{E}{qb}. \tag{25}$$

To calculate $x\dot{y} - y\dot{x}$ we notice that $\frac{d}{dt} (x\dot{y} - y\dot{x}) = x\ddot{y} - y\ddot{x}$ and replacing \ddot{x}, \ddot{y} according to (17) and (18), conformably, we shall have $\mu(x\ddot{y} - y\ddot{x}) = -\frac{1}{r} (x\dot{x} + y\dot{y} + z\dot{z}) = -\dot{r}$ wherefrom

$$\mu(x\dot{y} - y\dot{x}) = -r + A_0, \tag{26}$$

where a constant A_0 can be found from initial conditions (21) when considering (26) at $t = 0$ so $A_0 = \mu(x_0\dot{y}_0 - y_0\dot{x}_0) + r_0$ and

$$\mu(x\dot{y} - y\dot{x}) = -\sqrt{x^2 + y^2 + z^2} + \mu(x_0\dot{y}_0 - y_0\dot{x}_0) + r_0. \quad (27)$$

We can consider $A_0 \geq 0$ which always holds true for the strong enough field when $|b| \rightarrow \infty$ and, consequently, $\mu \rightarrow 0$. Then, considering (27) on z -axis where $x = y = 0$, we obtain $|z| = A_0$ which signifies that particle trajectory can reach z -axis only at $z = \pm A_0$. It should be recalled that according to Sect. 2 the z -axis is forbidden for motion of a particle so if for the particle $|z| = A_0$ at some moment then after it one should consider the motion to be finished and the particle vanished. Now, using (26), we can rewrite (25) as

$$\mu^2(x\ddot{x} + y\ddot{y} + z\ddot{z}) = \frac{A_0 - r}{r} \left(1 + \frac{z^2}{x^2 + y^2} \right) = \frac{A_0 - r}{r} (1 + \cot^2 \vartheta) \quad (28)$$

with spherical coordinate ϑ . At last, with the help of (28) we derive from (24)

$$\frac{d^2}{dt^2} r^2 = \frac{d}{dt} (2r\dot{r}) = 2 \left[v^2 + \frac{A_0 - r}{r\mu^2} (1 + \cot^2 \vartheta) \right]. \quad (29)$$

At $r \leq A_0$ from here it follows

$$\dot{r} = \frac{1}{r} \int \left[v^2 + \frac{A_0 - r}{r\mu^2} (1 + \cot^2 \vartheta) \right] dt > \frac{1}{A_0} \int v^2 dt > 0, \quad (30)$$

which signifies that r is increasing. But if $r \geq 2A_0$, i.e., $r - A_0 \geq A_0$, then $A_0/r \leq 1/2$ and from (30) we gain

$$\dot{r} = \frac{1}{r} \int \left[v^2 - \frac{1}{\mu^2} + \frac{A_0}{r\mu^2} - \frac{r - A_0}{r\mu^2} \cot^2 \vartheta \right] dt < \frac{1}{2A_0} \int \left(v^2 - \frac{1}{2\mu^2} \right) dt < 0, \quad (31)$$

provided that

$$v < \frac{1}{\sqrt{2}|\mu|} = \frac{|qb|}{\sqrt{2}E}, \quad (32)$$

i.e., r is decreasing. It should be emphasized that for sufficiently strong field ($|b| \rightarrow \infty$) the condition (32) will always be fulfilled for the given E . Besides, under this situation, $A_0 = \mu(x_0\dot{y}_0 - y_0\dot{x}_0) + r_0 \sim r_0$ and we can see that spherical coordinate r never tends to infinity and oscillates near the initial value r_0 . Inasmuch as, as said above, $r = r_0$, $\varphi = \varphi_0$ is a magnetic field line, then we can say that the particle trajectory oscillates near the magnetic field line defined by initial conditions. In other words, we get the full confinement of charged particle in the magnetic field under discussion which is sketched out in Fig. 2.

4 Asymptotical Expansions

To illustrate the general properties described in Sect. 3 it should be noted that the system (14)–(16) seems to be insoluble in an explicit form. But let us try to obtain an asymptotical solution of it in the form of expansions in the dimensionless parameter $\mu = E/(qb)$ in the strong field limit when $b \rightarrow \infty$, i.e., $\mu \rightarrow 0$. For this aim we can notice that the angle φ for Lagrangian L of (12) is the so-called cyclic coordinate, i.e. L does not depend on φ . Then

Fig. 2 Behaviour of a charged particle in the confining magnetic field

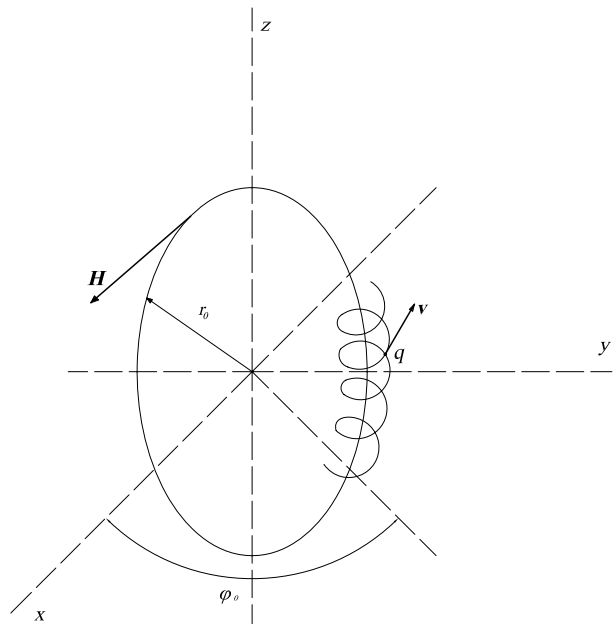

in accordance with the Lagrange approach we have an integral of motion (see (13)) in the form

$$\frac{\partial L}{\partial \dot{\varphi}} = Er^2 \dot{\varphi} \sin^2 \vartheta + q(br + B) = \alpha_\varphi = Er_0^2 \dot{\varphi}_0 \sin^2 \vartheta_0 + q(br_0 + B) = const, \quad (33)$$

with using the initial data of (20). From here it follows

$$\dot{\varphi} = \frac{v - r}{\mu r^2 \sin^2 \vartheta}, \quad v = r_0 + \mu r_0^2 \dot{\varphi}_0 \sin^2 \vartheta_0, \quad (34)$$

and it is not complicated to rewrite the system (14)–(16) in the form

$$\mu^2 \frac{dp}{dt} = \mu^2 \frac{s^2}{r^3} + \frac{v(v - r)}{r^3 \sin^2 \vartheta}, \quad (35)$$

$$\mu^2 \frac{ds}{dt} = \frac{(v - r)^2 \cos \vartheta}{r^2 \sin^3 \vartheta}, \quad (36)$$

$$\dot{r} = p, \quad (37)$$

$$\dot{\vartheta} = \frac{s}{r^2} \quad (38)$$

with $s = r^2 \dot{\vartheta}$.

4.1 Expressions for r and ϑ

Further we seek for r, ϑ, s, p in the form

$$\begin{aligned} r &= \bar{r}_0 + \mu \bar{r}_1 + \mu^2 \bar{r}_2 + O(\mu^3), & \vartheta &= \bar{\vartheta}_0 + \mu \bar{\vartheta}_1 + O(\mu^2), \\ s &= \bar{s}_0 + \mu \bar{s}_1 + O(\mu^2), & p &= \bar{p}_0 + \mu \bar{p}_1 + O(\mu^2), \end{aligned} \quad (39)$$

where $\bar{r}, \bar{r}_1, \bar{r}_2, \bar{\vartheta}_0, \bar{\vartheta}_1, \bar{s}_0, \bar{s}_1, \bar{p}_0, \bar{p}_1$ are some functions of t . Now, expanding the right-hand side of (35) in μ , we obtain

$$\mu^2(\dot{\bar{p}}_0 + \mu \dot{\bar{p}}_1) + O(\mu^4) = \frac{r_0(r_0 - \bar{r}_0)}{\bar{r}_0^3 \sin^2 \bar{\vartheta}_0} + O(\mu),$$

so we should have $\bar{r}_0 = r_0$.

Then the following terms of expansion for the right-hand side (35) give rise to relation

$$\mu^2(\dot{\bar{p}}_0 + \mu \dot{\bar{p}}_1) + O(\mu^4) = \frac{r_0^2 \dot{\varphi}_0 \sin^2 \bar{\vartheta}_0 - \bar{r}_1}{\bar{r}_0^2 \sin^2 \bar{\vartheta}_0} \mu + O(\mu^2),$$

which yields $\bar{r}_1 = r_0^2 \dot{\varphi}_0 \sin^2 \bar{\vartheta}_0 = \text{const}$. In this situation the new terms of expansion for the right-hand side (35) lead to

$$\mu^2(\dot{\bar{p}}_0 + \mu \dot{\bar{p}}_1) + O(\mu^4) = \left(\frac{\bar{s}_0^2}{r_0^3} - \frac{\bar{r}_2}{r_0^2 \sin^2 \bar{\vartheta}_0} \right) \mu^2 + O(\mu^3)$$

and it should be

$$\dot{\bar{p}}_0 = \frac{\bar{s}_0^2}{r_0^3} - \frac{\bar{r}_2}{r_0^2 \sin^2 \bar{\vartheta}_0}. \tag{40}$$

Let us now pass on to (36) where the conforming expansion with the help of (39) yields

$$\mu^2(\dot{\bar{s}}_0 + \mu \dot{\bar{s}}_1) + O(\mu^4) = \frac{\bar{r}_2^2 \cos \bar{\vartheta}_0}{r_0^2 \sin^3 \bar{\vartheta}_0} \mu^4 + O(\mu^5).$$

From here we have $\dot{\bar{s}}_0 = 0$ and, consequently, $\bar{s}_0 = C_0 = \text{const}$. Accordingly (37) gives rise to $\dot{\bar{r}}_0 + \mu \dot{\bar{r}}_1 + O(\mu^2) = \dot{\bar{p}}_0 + \mu \dot{\bar{p}}_1 + O(\mu^2)$ which entails $\dot{\bar{p}}_0 = \dot{\bar{r}}_0 = 0, \dot{\bar{p}}_1 = \dot{\bar{r}}_1 = 0$ since we have above obtained that $\bar{r}_0 = r_0, \bar{r}_1 = r_0^2 \dot{\varphi}_0 \sin^2 \bar{\vartheta}_0 = \text{const}$. In the circumstances the relation (40) gives

$$\bar{r}_2 = \frac{C_0^2}{r_0} \sin^2 \bar{\vartheta}_0. \tag{41}$$

At last, in a similar way from (38) we can obtain the relation

$$\dot{\bar{\vartheta}}_0 + \mu \dot{\bar{\vartheta}}_1 + O(\mu^2) = \frac{\bar{s}_0}{r_0^2} + O(\mu),$$

which entails $\dot{\bar{\vartheta}}_0 = \frac{\bar{s}_0}{r_0^2} = \frac{C_0}{r_0^2}$ and, as a result, $\bar{\vartheta}_0 = \frac{C_0}{r_0^2} t + C_1$ with some constant C_1 . Then, taking into account (39) and (41), we finally have

$$r = r_0 + \mu r_0^2 \dot{\varphi}_0 \sin^2 \bar{\vartheta}_0 + \mu^2 \frac{C_0^2}{r_0} \sin^2 \left(\frac{C_0}{r_0^2} t + C_1 \right) + O(\mu^3), \quad \vartheta = \frac{C_0}{r_0^2} t + C_1 + O(\mu). \tag{42}$$

4.2 Expression for φ

When searching for φ in the form $\varphi = \bar{\varphi}_0 + \mu \bar{\varphi}_1 + O(\mu^2)$ we shall, according to (34), obtain

$$\mu(\dot{\bar{\varphi}}_0 + \mu \dot{\bar{\varphi}}_1) + O(\mu^3) = -\frac{\bar{r}_2}{r_0^2 \sin^2 \bar{\vartheta}_0} \mu^2 + O(\mu^3),$$

wherefrom, with the help of (41), we get $\dot{\varphi}_0 = 0$, $\dot{\varphi}_1 = -\frac{C_0^2}{r_0^3}$ and, consequently, $\bar{\varphi}_0 = C_2$, $\bar{\varphi}_1 = -\frac{C_0^2}{r_0^3}t + C_3$ with some constants $C_{2,3}$. So finally

$$\varphi = C_2 + \left(C_3 - \frac{C_0^2}{r_0^3}t \right) \mu + O(\mu^2). \tag{43}$$

4.3 Determination of Constants

At $\mu \rightarrow 0$ with taking (20), (42) and (43) into account we find $C_0 \approx r_0^2 \dot{\vartheta}_0$, $C_1 \approx \vartheta_0$, $C_2 \approx \varphi_0$. This eventually leads to the final expressions

$$\begin{aligned} r &\approx r_0 + \mu r_0^2 \dot{\varphi}_0 \sin^2 \vartheta_0 + \mu^2 r_0^3 \dot{\vartheta}_0^2 \sin^2 (\dot{\vartheta}_0 t + \vartheta_0) + O(\mu^3), \\ \vartheta &\approx \vartheta_0 + \dot{\vartheta}_0 t + O(\mu), \quad \varphi \approx \varphi_0 + (C_3 - r_0 \dot{\vartheta}_0^2 t) \mu + O(\mu^2), \end{aligned} \tag{44}$$

that confirm the general considerations of Sect. 3 (see also Fig. 2).

5 Numerical Estimates

5.1 General Estimates

As is clear from (44), if we want a charged particle to be near magnetic field line $r = r_0$, $\varphi = \varphi_0$ defined by initial conditions then we should impose the condition $|\mu r_0^2 \dot{\varphi}_0 \sin^2 \vartheta_0| \ll r_0$ which entails

$$|\mu r_0 \dot{\varphi}_0 \sin^2 \vartheta_0| \ll 1, \quad \mu = \frac{E}{qb}. \tag{45}$$

If defining the physical components of velocity in spherical coordinates by equality $v^2 = (v_r^{ph})^2 + (v_\vartheta^{ph})^2 + (v_\varphi^{ph})^2 = g^{\mu\nu} v_\mu v_\nu = \dot{r}^2 + r^2 \dot{\vartheta}^2 + r^2 \sin^2 \vartheta \dot{\varphi}^2 = v_0^2 = \dot{r}_0^2 + r_0^2 \dot{\vartheta}_0^2 + r_0^2 \sin^2 \vartheta_0 \dot{\varphi}_0^2 = const$ then we get $v_r^{ph} = \dot{r}$, $v_\vartheta^{ph} = r \dot{\vartheta}$, $v_\varphi^{ph} = r \sin \vartheta \dot{\varphi}$ and the condition (45) signifies that $|\mu (v_0)_\varphi^{ph} \sin \vartheta_0| \leq |\mu v_0| \ll 1$.

But, obviously, $E = m/\sqrt{1 - v_0^2}$ so the condition $|\mu v_0| \ll 1$ can be rewritten as

$$\frac{mv_0}{\sqrt{(1 - v_0^2)4\pi N^2 \alpha_{em}}} \ll |b| \tag{46}$$

with $q = Ne$ and the electromagnetic coupling constant $\alpha_{em} = e^2/(4\pi) \approx 1/137.036$ in the chosen system of units.

5.2 Deuteron in Thermonuclear Plasma

For this case typical values $r_0 \sim 1$ m (see e.g. [17]) and at temperature of plasma $T \sim 0.8625 \times 10^{-2}$ MeV (10^8 K) we have a mean thermal deuteron velocity $v_0 \sim \sqrt{3T/m} \approx 0.372 \times 10^{-2}$ with the deuteron rest energy $m = m_p + m_n - 2.225$ MeV $\approx (938 + 939 - 2.225)$ MeV = 1874.775 MeV, $N = 1$ and (46) yields $|b| \gg 23.0$ MeV. Let us take $|b| = 1$

GeV and, for the sake of simplicity, put $\vartheta_0 = \pi/2$. Then in accordance with (A.17) the module of magnetic field strength near the particle trajectory will be

$$H = \frac{|b|}{r_0 \sin \vartheta_0} \sim 0.197 \times 10^{-15} \text{ GeV}^2 \sim 0.351 \text{ T}, \quad (47)$$

i.e., it is a quite accessible value under the laboratory conditions. It should be, however, noted that for the time t of order 1 s necessary to confine plasma before thermonuclear reaction starts [17] the angle ϑ can get increase $\vartheta_0 t = (v_0)_{\vartheta}^{ph} t / r_0 \sim v_0 t / r_0 \approx 10^6$ according to (44), i.e. promptness of particle along the magnetic field line $r = r_0$, $\varphi = \varphi_0$ (see Fig. 2) will approximately be equal to $N_0 = 10^6 / (2\pi) \approx 1.77 \times 10^5$, i.e., the particle will repeatedly cross z -axis which is impossible since the z -axis is forbidden for motion, as was mentioned in Sects. 2 and 3. But if $(v_0)_{\vartheta}^{ph} \rightarrow 0$ then $N_0 \rightarrow 0$ as well. We can draw the conclusion that deuteron rushing in to the field with $(v_0)_{\vartheta}^{ph} \approx 0$ will remain near its initial position during the time $t = 1$ s.

5.3 Quarks in Pions

We may with minor reservations try applying the results obtained also to quarks within hadrons, e.g., within charged pions π^{\pm} . In this case quarks are moving in the classical confining SU(3)-gluonic field (3) but they are quantum objects described by the wave functions—the modulo square integrable solutions of the Dirac equation in the field (3) (for more details see [8, 9, 12]). Let us, however, look at what the classical estimate (46) can give for quarks where, obviously, electric charge should be replaced by colour one and α_{em} by α_s , the strong coupling constant. We can use the fact [8, 9, 12] that the colour magnetic field between quarks can be characterized by an effective colour strength $H = b / (r \sin \vartheta)$ with $b = \sqrt{b_1^2 + b_1 b_2 + b_2^2}$ and $b_{1,2}$ from the solution (3) while r stands for the distance between quarks. Then (46) allow us to introduce quantity

$$b_0 = \frac{m v_0}{\sqrt{(1 - v_0^2) 4\pi \alpha_s}} \quad (48)$$

and for u -quark in π^{\pm} -mesons with $m = m_u \sim 2.25$ MeV, $v_0 \sim 0.99$, $\alpha_s \sim 0.485$ [12] we obtain $b_0 \approx 22.68$ MeV which at the scale of pion $r_0 \approx 0.672$ fm entails $H = b_0 / (r_0 \sin \vartheta) \sim 0.666 \times 10^{-2} \text{ MeV}^2 \sim 0.119 \times 10^{14} \text{ T}$ when $\vartheta = \pi/2$. In reality, from quantum considerations [12] for π^{\pm} -mesons it follows $b_1 = 0.178915$ GeV, $b_2 = -0.119290$ GeV so $b = \sqrt{b_1^2 + b_1 b_2 + b_2^2} \approx 0.157$ GeV $> b_0$ and at the scales of the meson under consideration we have [12] $H \sim (10^{15} - 10^{16})$ T. As a result, classical estimate corresponds to the quantum considerations.

6 Discussion and Concluding Remarks

It is useful to compare our results with the well-known case of motion of a charged particle in the homogeneous magnetic field (see, e.g., [16]) which is sketched out in Fig. 3. In the latter case the particle moves along helical curve with lead of helix $h = 2\pi m v \cos \alpha / (q H \sqrt{1 - v^2})$ and radius $R = m v \sin \alpha / (q H \sqrt{1 - v^2})$. As a consequence, the homogeneous magnetic field does not give rise to the full confinement of the particle

Fig. 3 Motion of a charged particle in the homogeneous magnetic field

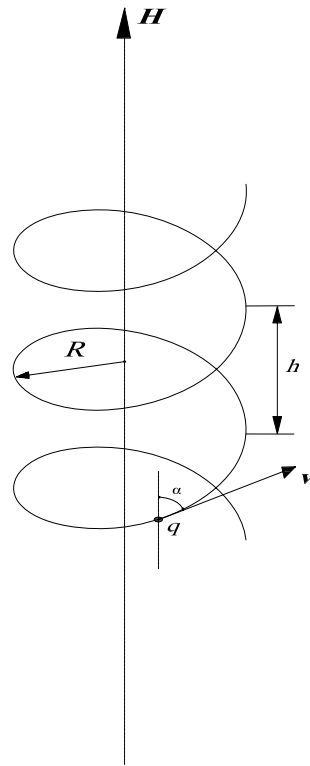

since the latter may go to infinity along the helical curve. Another matter is the case of the magnetic field (11). As we have seen above it provides the full confinement of any charged particle in case the field is strong enough: under any initial conditions the particle motion is accomplished within a finite region of space so that the particle trajectory is near magnetic field lines while the latter are compact manifolds (circles). This was explicitly demonstrated in Sect. 4 by obtaining asymptotical form of the motion under discussion.

Taking into account such remarkable properties of the magnetic field in question we may hope that it should find a number of applications, in particular, in thermonuclear plasma physics where the problem of confinement of plasma during a sufficiently long time has so far not solved in a satisfactory way [17]. But for it one should explore the possible ways of modeling the field (11) in laboratory conditions which is seemingly not such a simple task. One of possible physical realization is sketched out in Fig. 4 and is accomplished between two cone ferromagnetic pole pieces where the fact is used that magnetic field lines of ferromagnet are perpendicular to its surface. Of course, field lines inside the pole pieces (shown by dash lines) break off but if diameter $D \rightarrow 0$ while the pole pieces are approaching, the whole construction tends to the formal mathematical definition domain $\mathbb{R}^3 \setminus \{z\}$. In this realization it is clear why particles will leave the field: they will just be absorbed by pole pieces when moving along the field line. So one needs to fit parameters (in particular, the values of module H) of the whole construction in such a way that a particle could remain on trajectory for a long enough time t (e.g., for deuteron in thermonuclear plasma $t \sim 1$ s according to Sect. 5) not reaching the pole pieces.

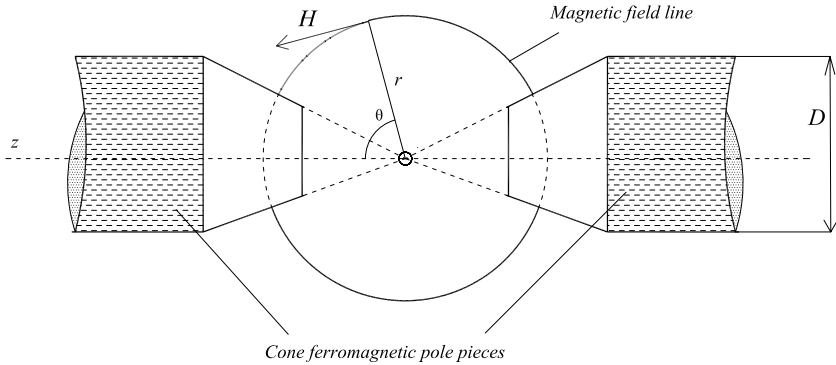

Fig. 4 One possible physical realization of the confining magnetic field

Finally, as has been said in Sect. 1, the main motivation of writing the given paper was to interpret the mechanism of quark confinement proposed in [1–3] in classical terms. As seems to us, we could to a certain degree do it.

Acknowledgements Yuri Goncharov is grateful to Prof. F. Nasredinov from Experimental Physics Department of the Sankt-Petersburg State Polytechnical University for discussion regarding the confining properties of the magnetic field of (11) and for pointing out the possible physical realization of it.

Appendix A

In main body of the paper we employ the formulation of vector analysis on a region Ω in \mathbb{R}^3 from [18]. To our mind such a formulation is most convenient especially while working with using the arbitrary curvilinear coordinates. The essence of that formulation is in systematical use of both the Hodge star operator $*$ and the exterior differential d .

Hodge Star Operator on \mathbb{R}^3 and Minkowski Spacetime

Let M is a smooth manifold of dimension n so we denote an algebra of smooth functions on M as $F(M)$. In a standard way the spaces as of smooth differential p -forms $\Lambda^p(M)$ ($0 \leq p \leq n$) are defined over M as modules over $F(M)$. If a (pseudo)riemannian metric $G = ds^2 = g_{\mu\nu}dx^\mu \otimes dx^\nu$ is given on M in local coordinates $x = (x^\mu)$ then G can naturally be continued on spaces $\Lambda^p(M)$ by relation

$$G(\alpha, \beta) = \det\{G(\alpha_i, \beta_j)\} \tag{A.1}$$

for $\alpha = \alpha_1 \wedge \alpha_2 \cdots \wedge \alpha_p, \beta = \beta_1 \wedge \beta_2 \cdots \wedge \beta_p$, where for 1-forms $\alpha_i = \alpha_\mu^{(i)}dx^\mu, \beta_j = \beta_\nu^{(j)}dx^\nu$ we have $G(\alpha_i, \beta_j) = g^{\mu\nu}\alpha_\mu^{(i)}\beta_\nu^{(j)}$ with the Cartan’s wedge (exterior) product \wedge . Under the circumstances the Hodge star operator $*$: $\Lambda^p(M) \rightarrow \Lambda^{n-p}(M)$ is defined for any $\alpha \in \Lambda^p(M)$ by

$$\alpha \wedge (*\alpha) = G(\alpha, \alpha)\omega_g \tag{A.2}$$

with the volume n -form $\omega_g = \sqrt{|\det(g_{\mu\nu})|}dx^1 \wedge \cdots \wedge dx^n$. For example, for 2-forms $F = F_{\mu\nu}dx^\mu \wedge dx^\nu$ we have

$$F \wedge *F = (g^{\mu\alpha}g^{\nu\beta} - g^{\mu\beta}g^{\nu\alpha})F_{\mu\nu}F_{\alpha\beta}\sqrt{\delta}dx^1 \wedge dx^2 \cdots \wedge dx^n, \mu < \nu, \alpha < \beta \tag{A.3}$$

with $\delta = |\det(g_{\mu\nu})|$. If s is the number of (-1) in a canonical presentation of quadratic form G then two the most important properties of $*$ are

$$*^2 = (-1)^{p(n-p)+s}, \tag{A.4}$$

$$*(f_1\alpha_1 + f_2\alpha_2) = f_1(*\alpha_1) + f_2(*\alpha_2) \tag{A.5}$$

for any $f_1, f_2 \in F(M)$, $\alpha_1, \alpha_2 \in \Lambda^p(M)$, i.e., $*$ is a $F(M)$ -linear operator. By virtue of (A.5) for description of $*$ -action in local coordinates it is enough to specify $*$ -action on the basis elements of $\Lambda^p(M)$, i.e. on the forms $dx^{i_1} \wedge dx^{i_2} \wedge \dots \wedge dx^{i_p}$ with $i_1 < i_2 < \dots < i_p$ whose number is equal to $C_n^p = \frac{n!}{(n-p)!p!}$.

The most important case of M in the given paper is a region Ω in the Euclidean space \mathbb{R}^3 with local Cartesian (x, y, z) or spherical (r, ϑ, φ) coordinates. The metric is given by either $ds^2 = dx^2 + dy^2 + dz^2$ or $ds^2 = dr^2 + r^2(d\vartheta^2 + \sin^2 \vartheta d\varphi^2)$, and we shall obtain the $*$ -action on the basis differential forms according to (A.2) in both the cases as

$$\begin{aligned} *dx &= dy \wedge dz, & *dy &= -dx \wedge dz, & *dz &= dx \wedge dy, \\ *(dx \wedge dy) &= dz, & *(dx \wedge dz) &= -dy, & *(dy \wedge dz) &= dx, \\ *(dx \wedge dy \wedge dz) &= 1, & *dr &= r^2 \sin \vartheta d\vartheta \wedge d\varphi, \end{aligned} \tag{A.6}$$

$$\begin{aligned} *d\vartheta &= -\sin \vartheta dr \wedge d\varphi, & *d\varphi &= \frac{1}{\sin \vartheta} dr \wedge d\vartheta, \\ *(dr \wedge d\vartheta) &= \sin \vartheta d\varphi, & *(dr \wedge d\varphi) &= -\frac{1}{\sin \vartheta} d\vartheta, \\ *(d\vartheta \wedge d\varphi) &= \frac{1}{r^2 \sin \vartheta} dr, & *(dr \wedge d\vartheta \wedge d\varphi) &= \frac{1}{r^2 \sin \vartheta}, \end{aligned} \tag{A.7}$$

so that on any p -form $*^2 = 1$, as should be in accordance with (A.4).

Let us also adduce for inquiring the conforming relations for the case of cylindrical coordinates ρ, φ, z , where $x = \rho \cos \varphi$, $y = \rho \sin \varphi$ and metric $ds^2 = d\rho^2 + \rho^2 d\varphi^2 + dz^2$. Then

$$\begin{aligned} *d\rho &= \rho d\varphi \wedge dz, & *d\varphi &= -\frac{1}{\rho} d\rho \wedge dz, & *dz &= \rho d\rho \wedge d\varphi, \\ *(d\rho \wedge d\varphi) &= \frac{1}{\rho} dz, & *(d\rho \wedge dz) &= -\rho d\varphi, & *(d\varphi \wedge dz) &= \frac{1}{\rho} d\rho, \\ *(d\rho \wedge d\varphi \wedge dz) &= \frac{1}{\rho}, \end{aligned} \tag{A.8}$$

where we can again see that $*^2 = 1$ on any p -form according to (A.4).

Also the important case of \overline{M} is Minkowski spacetime with coordinates t, r, ϑ, φ and metric $ds^2 = dt^2 - dr^2 - r^2(d\vartheta^2 + \sin^2 \vartheta d\varphi^2)$, where we have

$$\begin{aligned}
 *dt &= r^2 \sin \vartheta dr \wedge d\vartheta \wedge d\varphi, & *dr &= r^2 \sin \vartheta dt \wedge d\vartheta \wedge d\varphi, \\
 *d\vartheta &= -\sin \vartheta dt \wedge dr \wedge d\varphi, & *d\varphi &= \frac{1}{\sin \vartheta} dt \wedge dr \wedge d\vartheta, \\
 *(dt \wedge dr) &= -r^2 \sin \vartheta d\vartheta \wedge d\varphi, & *(dt \wedge d\vartheta) &= \sin \vartheta dr \wedge d\varphi, \\
 *(dt \wedge d\varphi) &= -\frac{1}{\sin \vartheta} dr \wedge d\vartheta, & *(dr \wedge d\vartheta) &= \sin \vartheta dt \wedge d\varphi, \\
 *(dr \wedge d\varphi) &= -\frac{1}{\sin \vartheta} dt \wedge d\vartheta, & *(d\vartheta \wedge d\varphi) &= \frac{1}{r^2 \sin \vartheta} dt \wedge dr, \\
 *(dt \wedge dr \wedge d\vartheta) &= \sin \vartheta d\varphi, & *(dt \wedge dr \wedge d\varphi) &= -\frac{1}{\sin \vartheta} d\vartheta, \\
 *(dt \wedge d\vartheta \wedge d\varphi) &= \frac{1}{r^2 \sin \vartheta} dr, & *(dr \wedge d\vartheta \wedge d\varphi) &= \frac{1}{r^2 \sin \vartheta} dt,
 \end{aligned} \tag{A.9}$$

so that on 2-forms $*^2 = -1$, as should be in accordance with (A.4). More details about the Hodge star operator can be found in [19].

At last, it should be noted that all the above is easily over linearity continued on the matrix-valued differential forms (see, e.g., [21]), i.e., on the arbitrary linear combinations of forms $a_{i_1 i_2 \dots i_p} dx^{i_1} \wedge dx^{i_2} \wedge \dots \wedge dx^{i_p}$, where coefficients $a_{i_1 i_2 \dots i_p}$ belong to some space of matrices V , for example, a SU(3)-Lie algebra. But now the Cartan’s wedge (exterior) product \wedge should be understood as product of matrices with elements consisting of usual (scalar) differential forms. In the SU(3)-case, if T_a are matrices of generators of the SU(3)-Lie algebra in 3-dimensional representation, we continue the above scalar product G on the SU(3)-Lie algebra valued 1-forms $A = A_\mu^a T_a dx^\mu$ and $B = B_\nu^b T_b dx^\nu$ by the relation

$$G(A, B) = g^{\mu\nu} A_\mu^a B_\nu^b \text{Tr}(T_a T_b), \tag{A.10}$$

where Tr signifies the trace of a matrix, and, on linearity with the help of (A.1), G can be continued over any SU(3)-Lie algebra valued forms. Such a matrix-valued generalization of $*$ -operator is extremely useful when exploring solutions of the Yang-Mills (and Maxwell) equations in Minkowski spacetime and was systematically employed in [1–3].

Operations of Vector Analysis in Terms of $*$ and d

The basic property of the exterior differential d is the same form in the arbitrary curvilinear coordinates x_i on Ω . Namely, $d = \sum_i \partial_{x_i} dx_i$ with $\partial_{x_i} = \partial/\partial x_i$. For example, in Cartesian and spherical coordinates we have, respectively, $d = \partial_x dx + \partial_y dy + \partial_z dz$ or $d = \partial_r dr + \partial_\vartheta d\vartheta + \partial_\varphi d\varphi$.

Passing on now to the vector analysis on Ω , we should note that it is usually formulated in Cartesian coordinates, where all main operations (divergence, curl operator and so on) look in the simplest form which makes difficulties when transferring to the arbitrary curvilinear coordinates. We can, however, simplify the situation if noting that there is one-to-one correspondence between any vector field $\mathbf{a} = a_x \mathbf{i} + a_y \mathbf{j} + a_z \mathbf{k}$ with $a_{x,y,z} = a_{x,y,z}(x, y, z)$ and 1-form $a_x dx + a_y dy + a_z dz$ so that the latter will be denoted by the same notation \mathbf{a} in what follows. When describing vector fields by 1-forms, however, we at once gain a number of advantages. Indeed, according to the standard rules [21] it is easy to get an expression of \mathbf{a} in the arbitrary curvilinear coordinates $x^i, i = 1, 2, 3$, if knowing x, y, z as the functions x^i . This is done by replacing $dx = (\partial x/\partial x^i) dx^i, dy = (\partial y/\partial x^i) dx^i,$

$dz = (\partial z/\partial x^i)dx^i$, $x, y, z = x, y, z(x^i)$ in the expression of \mathbf{a} in Cartesian coordinates and we at one blow obtain the components of \mathbf{a} in the given curvilinear coordinates—those are just the coefficients at the corresponding dx^i . Further, the basic products of vectors, scalar and vectorial ones, are now simply written through the conforming differential forms. Namely, scalar product $(\mathbf{a}, \mathbf{b}) \equiv \mathbf{a}\mathbf{b} = g^{\mu\nu}a_\mu b_\nu$, vectorial product $\mathbf{a} \times \mathbf{b} = *(\mathbf{a} \wedge \mathbf{b})$, where metric coefficients $g_{\mu\nu}$ and the Hodge star operator $*$ are defined by the expression ds^2 in the given curvilinear coordinates (see, e.g., (A.6)–(A.8)).

At last, we have the standard de Rham complex [18, 19]

$$F(\Omega) = \Lambda^0 \xrightarrow{d} \Lambda^1 \xrightarrow{d} \Lambda^2 \xrightarrow{d} \Lambda^3 \xrightarrow{d} 0, \tag{A.11}$$

which enables us to write down the main operations of vector analysis as

$$\text{grad } f = df = \frac{\partial f}{\partial x^i}dx^i, \quad \text{rot } \mathbf{a} = *(d\mathbf{a}), \quad \text{div } \mathbf{a} = *(d*\mathbf{a}) \tag{A.12}$$

with arbitrary function $f \in F(\Omega)$, so that, in virtue of the famous property $d^2 = 0$ for operator d , we automatically obtain the identities $\text{rot grad } f \equiv 0$, $\text{div rot } \mathbf{a} \equiv 0$, provided that the first and second de Rham cohomology groups of Ω are equal to zero: $H^1\Omega = H^2\Omega = 0$. It should be emphasized that relations (A.12) hold true for any curvilinear coordinates as soon as the expression of metric ds^2 is fixed in those coordinates and, accordingly, the Hodge star operator action is defined on any p -form. After computing with using the given curvilinear coordinates we can always return to Cartesian ones by replacing $dx^i = (\partial x^i/\partial x)dx + (\partial x^i/\partial y)dy + (\partial x^i/\partial z)dz$, $dx \rightarrow \mathbf{i}$, $dy \rightarrow \mathbf{j}$, $dz \rightarrow \mathbf{k}$.

Many relations of vector analysis obtained in Cartesian coordinates can easily be generalized to the arbitrary curvilinear coordinates within the formulation under consideration. For example, the identities

$$\text{div}(\mathbf{a} \times \mathbf{b}) = (\text{rot } \mathbf{a})\mathbf{b} - \mathbf{a}(\text{rot } \mathbf{b}), \tag{A.13}$$

$$\text{rot}(\mathbf{a} \times \mathbf{b}) = (\mathbf{b}\nabla)\mathbf{a} - (\mathbf{a}\nabla)\mathbf{b} + \text{div}(\mathbf{b})\mathbf{a} - \text{div}(\mathbf{a})\mathbf{b} \tag{A.14}$$

acquire the form

$$\text{div}(\mathbf{a} \times \mathbf{b}) = *d(\mathbf{a} \wedge \mathbf{b}), \tag{A.15}$$

$$\text{rot}(\mathbf{a} \times \mathbf{b}) = *d*(\mathbf{a} \wedge \mathbf{b}) \tag{A.16}$$

holding true for any curvilinear coordinates. On the other hand, if trying to use (A.13)–(A.14) within framework of the standard formulation, e.g., in spherical coordinates, then this will lead to the perfectly bulky expressions. At the same time, the right-hand sides of (A.15)–(A.16) are easily computed for concrete \mathbf{a} and \mathbf{b} in any curvilinear coordinates along the lines above.

The Confining Magnetic Field

To illustrate some of the above let us compute the strength \mathbf{H} of the confining magnetic field of (8)–(9) in Cartesian coordinates. By definition we have $\mathbf{H} = \text{rot } \mathbf{A}$ and in spherical coordinates $\mathbf{A} = (br + B)d\varphi$. Then in accordance with (A.12) and (A.7) $\mathbf{H} = *(d\mathbf{A}) = *d[(br + B)d\varphi] = *(bdr \wedge d\varphi) = -\frac{b}{\sin\vartheta}d\vartheta = H_\vartheta d\vartheta$ which entails the module

$$H = \sqrt{g^{\mu\nu}H_\mu H_\nu} = \sqrt{g^{\vartheta\vartheta}H_\vartheta^2} = \frac{|b|}{r \sin\vartheta}.$$

On the other hand, $\vartheta = \arccos \frac{z}{r} = \arccos \frac{z}{\sqrt{x^2+y^2+z^2}}$ wherefrom

$$d\vartheta = \frac{\partial\vartheta}{\partial x}dx + \frac{\partial\vartheta}{\partial y}dy + \frac{\partial\vartheta}{\partial z}dz = \frac{xz}{r^2\sqrt{x^2+y^2}}dx + \frac{yz}{r^2\sqrt{x^2+y^2}}dy - \frac{\sqrt{x^2+y^2}}{r^2}dz.$$

At last, $\sin \vartheta = \frac{\sqrt{x^2+y^2}}{r}$ and we get

$$\mathbf{H} = -\frac{b}{\sin \vartheta}d\vartheta = -\frac{b}{r}\left(\frac{xz}{x^2+y^2}dx + \frac{yz}{x^2+y^2}dy - dz\right)$$

or, using the above isomorphism $dx \iff \mathbf{i}$, $dy \iff \mathbf{j}$, $dz \iff \mathbf{k}$,

$$\mathbf{H} = -\frac{b}{r}\left(\frac{xz}{x^2+y^2}\mathbf{i} + \frac{yz}{x^2+y^2}\mathbf{j} - \mathbf{k}\right), \tag{A.17}$$

so the module $H = \sqrt{H_x^2 + H_y^2 + H_z^2} = \frac{|b|}{\sqrt{x^2+y^2}} = \frac{|b|}{r \sin \vartheta}$.

Appendix B

The facts adduced here have been obtained in [2, 3] and we concisely give them only for completeness of discussion in Sect. 2.

For the case of U(1)-group the Yang-Mills equations (1) turn into the second pair of Maxwell equations

$$d * F = 0 \tag{B.1}$$

with $F = dA$, $A = A_\mu dx^\mu$. The most general ansatz for a spherically symmetric solution is $A = A_t(r)dt + A_r(r)dr + A_\vartheta(r)d\vartheta + A_\varphi(r)d\varphi$.

For the latter ansatz we have $F = dA = -\partial_r A_t dt \wedge dr + \partial_r A_\vartheta dr \wedge d\vartheta + \partial_r A_\varphi dr \wedge d\varphi$ for an arbitrary $A_r(r)$. Then, according to (A.9), we obtain

$$*F = (r^2 \sin \vartheta)\partial_r A_t d\vartheta \wedge d\varphi + \sin \vartheta \partial_r A_\vartheta dt \wedge d\varphi - \frac{1}{\sin \vartheta} \partial_r A_\varphi dt \wedge d\vartheta \tag{B.2}$$

which entails

$$\begin{aligned} d * F &= \sin \vartheta \partial_r (r^2 \partial_r A_t) dr \wedge d\vartheta \wedge d\varphi - \sin \vartheta \partial_r^2 A_\vartheta dt \wedge dr \wedge d\varphi \\ &\quad - \cos \vartheta \partial_r A_\vartheta dt \wedge d\vartheta \wedge d\varphi + \frac{1}{\sin \vartheta} \partial_r^2 A_\varphi dt \wedge dr \wedge d\vartheta, \end{aligned} \tag{B.3}$$

wherefrom one can conclude that

$$\partial_r (r^2 \partial_r A_t) = 0, \quad \partial_r^2 A_\varphi = 0, \tag{B.4}$$

$$\partial_r^2 A_\vartheta = \partial_r A_\vartheta = 0, \tag{B.5}$$

and we draw the conclusion that $A_\vartheta = C_1$ with some constant C_1 . But then the Lorentz condition (2) for the given ansatz gives rise to

$$\sin \vartheta \partial_r (r^2 A_r) + \partial_\vartheta (\sin \vartheta A_\vartheta) = \sin \vartheta \partial_r (r^2 A_r) + \partial_\vartheta (C_1 \sin \vartheta) = 0,$$

or

$$\partial_r(r^2 A_r) + C_1 \cot \vartheta = 0, \quad (\text{B.6})$$

which yields $A_r = -C_1 \cot \vartheta / r + C_2 / r^2$ with a constant C_2 . But the confining solutions should be spherically symmetric and contain only the components which are Coulomb-like or linear in r , so one should put $C_1 = C_2 = 0$. Consequently, the ansatz $A = A_t(r)dt + A_\varphi(r)d\varphi$ is the most general spherically symmetric one and then equations (B.4) give

$$A_t = \frac{a}{r} + A, \quad A_\varphi = br + B \quad (\text{B.7})$$

with some constants a, b, A, B parametrizing solutions which proves the uniqueness theorem of Sect. 2 for U(1)-group. Minor modification of the above considerations allows us to spread the proof to the Yang-Mills equations (1) (for more details see [2, 3]).

References

1. Goncharov, Yu.P.: Mod. Phys. Lett. A **16**, 557 (2001)
2. Goncharov, Yu.P.: Phys. Lett. B **617**, 67 (2005)
3. Goncharov, Yu.P.: In: Kreitler, P.V. (ed.) New Developments in Black Hole Research, pp. 67–121. Nova Science Publishers, New York (2006). Chap. 3, [hep-th/0512099](https://arxiv.org/abs/hep-th/0512099)
4. Goncharov, Yu.P.: Europhys. Lett. **62**, 684 (2003)
5. Goncharov, Yu.P., Choban, E.A.: Mod. Phys. Lett. A **18**, 1661 (2003)
6. Goncharov, Yu.P., Bytsenko, A.A.: Phys. Lett. B **602**, 86 (2004)
7. Goncharov, Yu.P.: Nucl. Phys. A **808**, 73 (2008)
8. Goncharov, Yu.P.: Phys. Lett. B **641**, 237 (2006)
9. Goncharov, Yu.P.: Phys. Lett. B **652**, 310 (2007)
10. Goncharov, Yu.P.: Mod. Phys. Lett. A **22**, 2273 (2007)
11. Goncharov, Yu.P.: J. Phys. G, Nucl. Part. Phys. **35**, 095006 (2008)
12. Goncharov, Yu.P.: Nucl. Phys. A **812**, 99 (2008)
13. Ryder, L.H.: Quantum Field Theory. Cambridge University Press, Cambridge (1985)
14. Wilson, K.: Phys. Rev. D **10**, 2445 (1974)
15. Bander, M.: Phys. Rep. **75**, 205 (1981)
16. Landau, L.D., Lifshits, E.M.: Field Theory. Nauka, Moscow (1988)
17. Glukhikh, V.A., Belyakov, V.A., Mineev, A.B.: Physical and Technical Foundations of the Controlled Thermonuclear Fusion. Sankt-Petersburg State Polytechnical University Press, Sankt-Petersburg (2006)
18. Postnikov, M.M.: Smooth Manifolds. Nauka, Moscow (1987)
19. Besse, A.L.: Einstein Manifolds. Springer, Berlin (1987)
20. Postnikov, M.M.: Riemannian Geometry. Factorial, Moscow (1998)
21. Cartan, H.: Calcul Différentiel. Formes Différentiel. Hermann, Paris (1967)